Phase Separator

Stainless steel, vacuum insulated vessels designed to store liquid nitrogen under atmospheric pressure. Phase Separators are used in specialized applications requiring extremely high quality, low pressure liquid nitrogen on demand. The level of liquid nitrogen inside is controlled electronically via a pressure differential system. The reservoir is vented to atmosphere at all times ensuring that the pressure inside is equal to atmosphere. This results in a volume of pure unsaturated liquid nitrogen. Chart's Phase Separator is a vacuum insulated reservoir holding tank for liquid nitrogen.

Typical applications include both direct feed or closed loop systems. A closed loop system is typically used to feed a cryopanel in an MBE (molecular beam epitaxy) application. Static Chart pipes are used to feed liquid nitrogen into the Phase Separator. Specialty triaxial pipe delivers pure liquid nitrogen for the Phase Separator to the application tool inlet.



Features

- Differential Pressure Controls and Proportional Inlet Valve - tried and proven method to maintain a constant level of cryogenics
- Ready Supply of Pure Liquid - mandatory for critical applications, testing, and processes
- High Volume Phase Separators - for custom applications requiring more capacity
- Static Pipe Compatible - available in static vacuum design
- Triax Compatible - eliminates two phase flow of liquid nitrogen to use points
- Warranty - two (2) year warranty against manufacturing defects from time of shipment

Key Benefits

- Low Pressure LN₂ - stored at atmospheric pressure to gravity feed LN₂
- Pure LN₂ Delivery - LN₂ at atmospheric pressure guarantees highly saturated LN₂ delivery
- Closed Loop System - re-circulate and re-use LN₂ through the Phase Separator and custom designed triax pipe
- On Demand LN₂ - LN₂ is stored in the Phase Separator for immediate, on demand consumption



Phase Separator Technical Specifications

Materials	Stainless Steel 300
Controller Dimensions	14"H x 6.5"D x 2.5" W (356 mm H x 165 mm D x 64 mm W)
Number of Outlets	2 to 10 (even increments)
Capacity/Operational Volume	2 & 4 outlets: 4.63 gallons (17.53 liters) 6, 8, & 10 outlets: 12.19 gallons (46.14 liters)
Weight	Empty Condition: 60 - 85 lbs (27.2 - 38.6 kg) Full Condition: 100 - 163 lbs (45.4 - 73.9 kg)
System Utilities	Electricity: 110 - 220VAC, 50 - 60Hz Gaseous Nitrogen: Minimum 50 psi (3.45 bar), maximum 100 psi (6.89 bar) Liquid Nitrogen: Maximum 125 psi (8.62 bar); 80 psi (5.52 bar) optimal
Certifications	NE MA 4X, CE
Options	Custom sizes, ASME coded pressure vessels, backpressure regulator (10 psi/0.7 bar max)

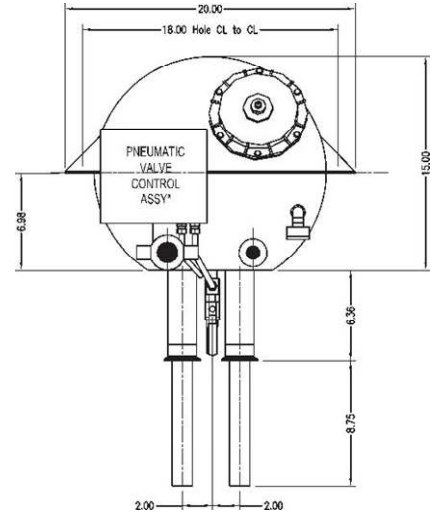

Phase Separator Diagram

